

WARRIOR SERIES USER MANUAL (FULL VERSION)

SW Ver. 1.24

3136611513 - Revision A, Apr 2014



CONTENTS

1.0	INTRODUCTION	2
2.0	SPECIFICATIONS	3
3.0	INSTALLATION	4
3.1	UNPACKING	4
3.2	LOCATING.....	4
3.3	SETTING UP THE SCALES.....	5
4.0	KEY DESCRIPTIONS.....	6
5.0	DISPLAYS	8
6.0	OPERATION.....	9
6.1	ZEROING THE DISPLAY	9
6.2	TARING	9
6.3	WEIGHING A SAMPLE	10
6.4	PARTS COUNTING.....	11
6.5	CHECK-WEIGHING	12
6.6	ACCUMULATED TOTAL.....	13
6.7	PERCENT WEIGHING	14
6.8	ANIMAL (DYNAMIC) WEIGHING.....	16
7.0	USER PARAMETERS.....	18
7.1	CHECK WEIGHING PARAMETERS.....	18
7.2	PERCENT WEIGHING and ANIMAL WEIGHING.....	19
7.3	RS-232 PARAMETERS.....	20
7.4	SCALE PARAMETERS	21
8.0	BATTERY OPERATION	23
9.0	RS-232 INTERFACE	24
9.1	INPUT COMMANDS FORMAT	28
10.0	RELAY INTERFACE.....	29
11.0	CALIBRATION.....	31
12.0	SERVICE PARAMETERS	32
12.1	USING "1000" TO ENTER THE SERVICE PARAMETERS.....	32
12.2	USING THE SERVICE PARAMETERS	33
13.0	ERROR CODES	36
14.0	REPLACEMENT PARTS AND ACCESSORIES.....	37
15.0	SERVICE INFORMATION.....	38
16.0	WARRANTY INFORMATION.....	39

1.0 INTRODUCTION

- The Adam Equipment **WARRIOR** series provide accurate, fast and versatile general purpose type weighing scales with parts counting, percentage weighing and check-weighing functions.
- The **WARRIOR** has LED's next to the display to indicate when a weight is below the low limit, in between the limits or above the high limit. These can work in conjunction with an audible alarm for check weighing as well as the display showing LOW, OK and HI.
- The **WARRIOR** is supplied with a RS-232 bi-directional interface and real time clock (RTC).
- The **WARRIOR** has a sealed keypad with colour coded membrane switches, a large easy to read liquid crystal display (LCD) and a green backlight.
- Included functions are automatic zero tracking, semi-automatic tare and an accumulation facility that allows the weight to be stored and recalled as an accumulated total.

2.0 SPECIFICATIONS

Model #	WSK 8 WSK 16a	WSK 16 WSK 35a	WSK 32 WSK 70a	WBK 32 WBK 70a	WBK 32H WBK70aH	WBK 75 WBK 165a
Maximum Capacity	8000g/16lb	16kg/35lb	32kg/70lb	32kg/70lb	32kg/70lb	75kg/165lb
Readability	0.5g/0.001lb	0.001kg/ 0.002lb	0.002kg/ 0.005lb	0.002kg/ 0.005lb	0.001kg/ 0.002lb	0.005kg/ 0.01lb
Resolution	1:16000	1:16000	1:16000	1:16000	1:32000	1:15000
Repeatability (Std. Dev)	1g/0.002lb	0.002kg/ 0.004lb	0.004kg/ 0.01lb	0.004kg/ 0.01lb	0.002kg/ 0.004lb	0.01kg/ 0.02lb
Linearity \pm	1g/0.002lb	0.002kg/ 0.004lb	0.004kg/ 0.01lb	0.004kg/ 0.01lb	0.002kg/ 0.004lb	0.01kg/ 0.02lb
Pan size w x d	250mm x 250mm/ 9.8in x 9.8in			300mm x 400mm/ 11.8in x 15.7in		
Units of Measure	g / Kg / Lb / Lb:oz / Newtons / Ounces					

Model #	WFK 75 WFK 165a	WFK 75H WFK 165aH	WFK 150 WFK 330a	WLK 150 WLK 330a
Maximum Capacity	75kg/165lb	75kg/165lb	150kg/330lb	150kg/330lb
Readability	0.005kg/0.01lb	0.001kg/0.002lb	0.01kg/0.02lb	0.01kg/0.02lb
Resolution	1:15000	1:75000	1:15000	1:15000
Repeatability (Std. Dev)	0.01kg/0.02lb	0.002kg/0.004lb	0.02kg/0.04lb	0.02kg/0.04lb
Linearity \pm	0.01kg/0.02lb	0.002kg/0.004lb	0.02kg/0.04lb	0.02kg/0.04lb
Pan size w x d	400mm x 500mm/ 15.7in x 19.7in			450mm x 600mm/ 17.7in x 23.6in
Units of Measure	g / Kg / Lb / Lb:oz / Newtons/Ounces			





COMMON SPECIFICATIONS FOR ALL MODELS	
Stabilization Time	2-3 Secs
Operating Temperature	-10°C to +40°C / +32°F to +104°F
Power Supply	+ 6v 4.5Ah battery 12vDC 800mA External adaptor
Calibration	External
Calibration Mass	User Selectable
Display	Backlit Green display 40mm high digits with capacity tracker
Balance Housing	304 Stainless steel housing, IP66 rated

3.0 INSTALLATION

3.1 UNPACKING

The **WARRIOR** scales have already been adjusted to work with a platform and have been configured for this application. The platform and indicator have been calibrated as a pair and must be used together.

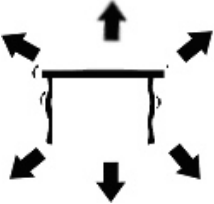
3.2 LOCATING

	<ul style="list-style-type: none">• The scales should not be placed in a location that will reduce the accuracy.• Avoid extremes of temperature. Do not place in direct sunlight or near air conditioning vents.
	<ul style="list-style-type: none">• Avoid unsuitable tables. The table or floor must be rigid and not vibrate.• Avoid unstable power sources. Do not use near large users of electricity such as welding equipment or large motors.
	<ul style="list-style-type: none">• Do not place near vibrating machinery.• Avoid high humidity that might cause condensation. Avoid direct contact with water. Do not spray or immerse the scales in water.• Avoid air movement such as from fans or opening doors. Do not place near open windows or air-conditioning vents.
	<ul style="list-style-type: none">• Keep the scales clean. Do not stack material on the scales when they are not in use.

3.3 **SETTING UP THE SCALES**

- Remove the Indicator from its box and fix it to the U shaped bracket using the 2 x fixing handles. Take the Indicator and place it onto the pillar ensuring the slack cable is pushed inside. Fix the Indicator to the pillar using the screw provided.
- Remove all upper internal packaging, place the pillar into the base bracket fitting and remove the complete machine from the box. Remove any plastic bags that may have been used for protection.
- Fix the pillar to the base bracket fitting using the screws provided
- Adjust the viewing angle of the Indicator to the ideal position and tighten the 2 x locking handles.
- Level the scale by adjusting the five feet on the WSK/WBK or the four feet on the WFK/WLK until the bubble is in the centre of the level indicator. If the scale rocks, re-adjust the feet.



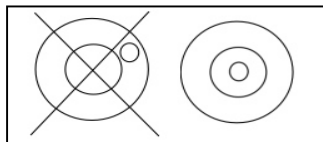



NOTE: Use of a food-safe grease is recommended on the threaded part of the feet to keep them turning freely.

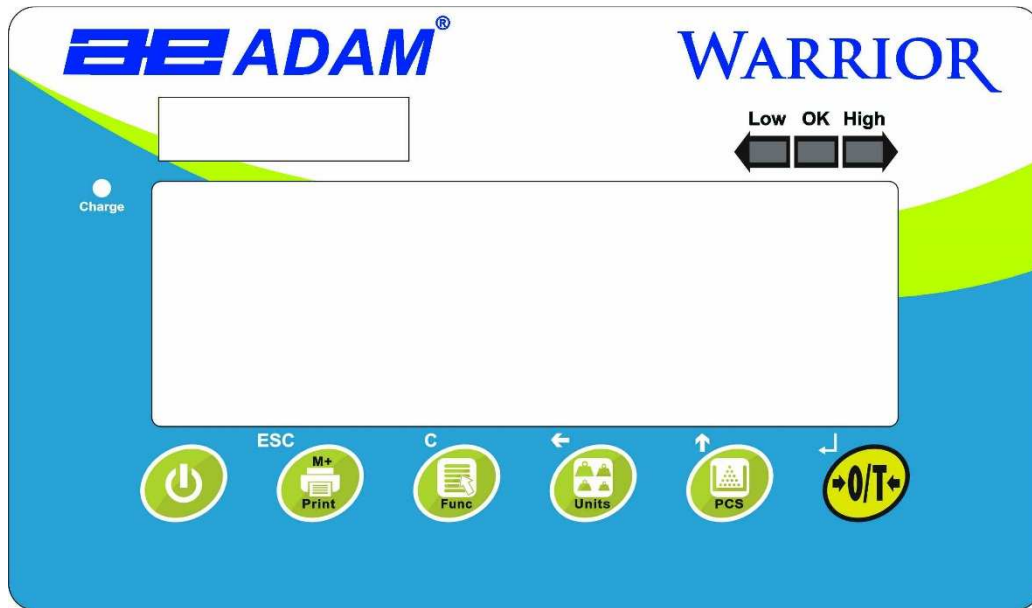

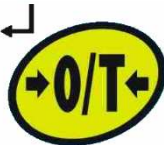

- Attach the power input connector to the indicator, plug in and turn on the external power supply and press the **[On/Off]** key. The software revision number will be displayed followed by a self-test showing all digits before the zero is displayed along with the unit of weight that was last used.
- Optional connections to RS232 port and relay wiring port should be made if required.

4.0 KEY DESCRIPTIONS



	<p>Used to reset the display to zero.</p> <p>Tares the scale. Used to deduct and store the weight currently on the scale if it is not required as part of the final weighing result.</p> <p>A secondary function,  is of an “Enter” key used when setting up a value for the Parameters.</p>
	<p>Selects parts counting. Used to set the sample quantities while parts counting.</p> <p>A secondary function,  is of incrementing the active digit when setting a value for Parameters.</p>
	<p>Selects the weighing unit to be displayed from those which are enabled. See parameter S1 in section 7.4 of this manual.</p> <p>A secondary function,  is to move the active/flashing digit to the left when setting values for Parameters.</p>

<p>C</p> 	<p>Selects the Function parameters of the scale.</p> <p>A secondary function (C) is to act as a clear key when clearing an accumulated total.</p>
<p>ESC</p> 	<p>Sends the results to a PC or a Printer using the RS-232 interface. It also adds the value to the accumulation memory if the accumulation function is not automatic.</p> <p>A secondary function (ESC) is to return to normal operation when the scale is in a Parameter setting mode.</p>
	<p>To switch the Indicator on or off.</p> <p>The WARRIOR will store the weighing unit and the check weighing values currently in use if power is powered off. These will be re called when the Indicator is next powered on</p>

5.0 DISPLAYS

The LCD display will show a value as well as the unit currently being used. In addition the LED's above the display will show when a weight is below, inside or above the check-weighing limits.

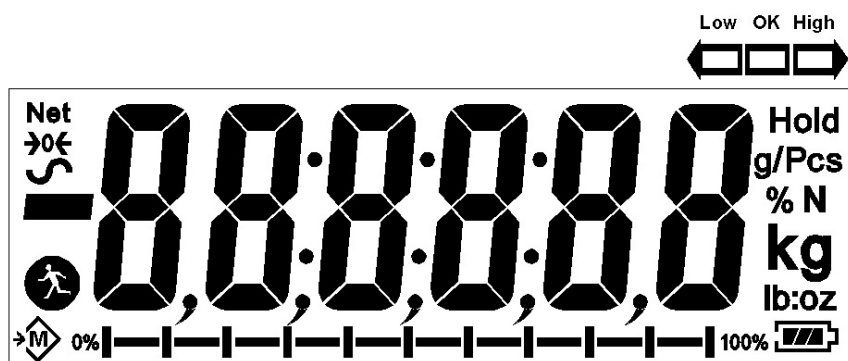

Other symbols will show when a weight has been tared (NET), the scale is at zero and stable, if a value has been stored in memory, or when the animal weighing function has been enabled. A battery bar symbol will show the state of charge of the internal battery.

6.0 OPERATION

6.1 ZEROING THE DISPLAY

- You can press the [→0/T←] key at any time to set the display to zero. This will usually be when the platform is empty. When the zero point is obtained the display will show an indicator for zero.



- The scale has an automatic re-zeroing function to account for minor drifting or accumulation of material on the platform. However you may need to press the [→0/T←] key to re zero the scale if small amounts of weight are shown when the platform is empty.

6.2 TARING

- Zero the scale by pressing the [→0/T←] key if necessary. The “ZERO” indicator will be ON.



- Place a container on the platform and a value for its weight will be displayed.

- Press the [→0/T←] key to tare the scale. The weight is deducted and stored as the tare value leaving zero on the display. The “NET” indicator will be ON and as a product is added only the net weight of the product will be shown. The scale could be tared a second time if another type of product was to be added to the first one. Again only the weight that is added after taring will be displayed.



NOTE: The “NET” indicator will only be ON when the tare weight exceeds 4% (+/- 2weighing divisions) of the scale capacity.

- When the container is removed a negative value will be shown. If the scale was tared just before removing the container this value is the gross weight which includes the container and the entire product it contains. The “ZERO” indicator will be on to indicate that the platform is back to the same condition as it was when zero was last set.
- To delete a Tare value, press [→0/T←] when the pan is empty.

6.3 WEIGHING A SAMPLE

To determine the weight of a sample, first tare the empty container if it is to be used and then place the sample in the container. The display will show the net weight of the sample and the unit of weight currently in use.



6.4 PARTS COUNTING

If parts counting is enabled, it is possible to count parts using a sample of the parts to determine average piece weight.

- Before starting, tare the weight of any container that may be used, leaving the empty container on the scale. Place a known number of samples in the container, if used. The number should match the options for parts counting, i.e., 10, 20, 50, 100 or 200 pieces.
- When the scale is showing weight, pressing the **[Pcs/↑]** key will start the parts counting function.
- The scale will show “P 10” asking for a sample size of 10 parts. Change the sample size to the desired quantity by pressing the **[Pcs/↑]** key. It will cycle through the options: 10, 20, 50, 100, 200 and back to 10.



- Press the **[→0/T←]** key again when the number matches the number of parts used as the sample. As more weight is added the display will show the number of parts (Pcs).



- Pressing the **[Unit/←]** key will display the net weight (pcs and kg), pressing it second time will display the unit weight (g/pcs) and the third time, it will be the count again (pcs).

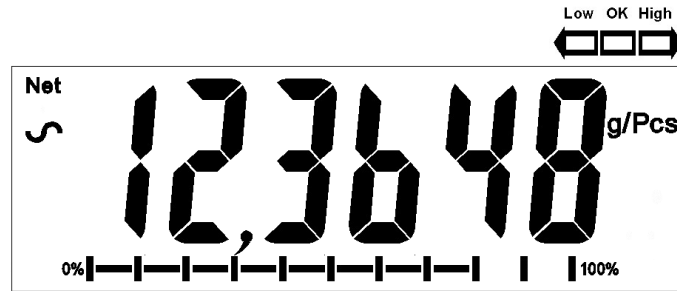

- Press the **[Pcs/↑]** key to return to normal weighing. Press the **[Pcs/↑]** key again to start counting a different sample.

6.5 CHECK-WEIGHING

Check-weighing is a procedure to cause lamps to come on (and if enabled, an alarm to sound) when the weight on the scale meets or exceeds values stored in memory. The memory holds the last values for a high and a low limit when the power is turned off. The user can set either one limit or both as described in section 7.1. The limits can be set when the scale is in weighing or parts counting modes. After limits have been set the Check-weighing function is enabled.

When a weight is placed on the scale the LED's above the display will show if the weight is above or below the limits and the beeper will sound as described below, if the beeper is enabled (see section 7.1).

The relay outputs are open collector drivers to control an external relay. The relays will be active when the corresponding LED is on during check-weighing. The ZERO relay output will be on when the scale is showing the display is at Zero.

6.6 ACCUMULATED TOTAL

- The scale can be set to accumulate manually by pressing the **[Print/M+/Esc]** key or automatically when a weight is removed from the scale. See the Section 7.3 for details of setting the Parameter “**C3 PRM**” and “**C4 Aon**”. The accumulation function is available when weighing or when counting parts. However the memory is cleared if the weighing units or functions are changed.
- When the weight (or count) displayed is stored in memory the display will show “**ACC 1**” and then the total in memory for 2 seconds before returning to weighing. The RS-232 interface will output to a printer or PC.
- Remove the weight, allowing the scale to return to zero and put a second weight on. When this value is stored, the display will show “**ACC 2**”, then the new total and finally the value of the second weight. Repeat as necessary to add all the values needed to the memory.
- To view the total in memory press the **[Print/M+/Esc]** key when there is no weight on the scale. The display will show the number of entries and the total.
- To clear the memory (set the value to zero) press the **[Func/C]** key during the time the totals are being displayed.

6.7 PERCENT WEIGHING

The scale can be set to perform percent weighing. See Section 7.2.

The scale will use a mass on the platform as the 100% reference weight. If the platform is empty (or the scale is tared) then the user can input a reference weight using the keypad.

NOTE: The weight value entered as 100% must be greater than 50 scale divisions. The display may jump by large numbers unexpectedly if small weights are used to set as 100% reference. The scale checks if the weight is too small and will show Error 7

- Press **[Func/C]**. The first option is “**Func 1**”. press the **[Func/C]** key again display “**Func 2**”.



- Press the **[→0/T←]** key. “**P1 Pct**” will be displayed.

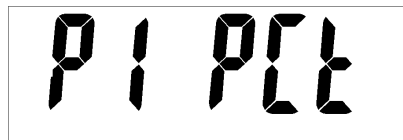

- Press **[→0/T←]** again to enter percent weighing. The scale will set the sample mass on the platform as 100% reference weight.



- Remove the sample weight. Then any other weight placed on the scale will be displayed as a percentage of the original sample. For example, if 3500g is placed on the scale and percent weighing is selected, the display will show 100.0%. Remove the 3500g weight and place a 3000g weight. The display will show 85.7% as 3000g is 85.7% of 3500g.



- The number of decimal points will depend on the weight used in comparison to the capacity of the system. A smaller weight will show only “**100%**” while a

larger weight might show “**100.00%**”.

- If the scale was showing zero weight when entering this function, then the user must manually enter the weight to be set as 100% as described below.
- Press the [**→0/T←**] key. “**P1 Pct**” will be displayed.
- Press [**→0/T←**] again to enter percent weighing. The scale will now accept a value the user enters as the reference weight.
- Enter the value using the [**Unit/←**] key and [**Pcs/↑**] key to select and set the value of the 100% mass.
- When set, press the [**→0/T←**] key to store the value. The display will show “**0.00 %**”.
- Press [**Unit/←**] to return to weighing.

6.8 ANIMAL (DYNAMIC) WEIGHING

The scale can be set to animal (dynamic) weighing for weighing any items that are unstable or may move. See Section 7.4.

The scale will use a special filter to minimise the effects of any movement while the moving animal or unstable samples are on the scale.

- Press **[Func/C]**. The first option is **"Func 1"**, press the **[Func/C]** key again to display **"Func 2"**.



The image shows a digital display with the text "Func 2" in a large, black, monospaced font. The characters are slightly spaced out, and the background is white.

- Press the **[→0/T←]** key. **"F1 Pct"** will be displayed. Press the **[Pcs/↑]** key to advance to the second function, **"P2 Ani"**, Animal weighing.

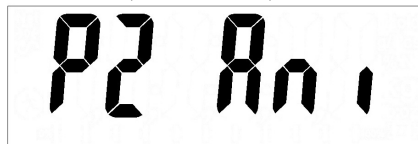

The image shows a digital display with the text "P2 Ani" in a large, black, monospaced font. The characters are slightly spaced out, and the background is white.

- Press **[→0/T←]** to enter animal weighing. The scale will change to animal weighing and allow weighing of an unstable animal or sample on the platform.
- To use the Animal Weighing function it is necessary to set the amount of filtering required for the item to be weighed. The display will show **"Fltx"** where **x** is a value from 1 to 5. The higher the value the greater the amount of filter will be. More active animals will require a higher level of filtering to give a stable result. To increment the value shown, press the **[Pcs/↑]** key then press the **[→0/T←]** key to accept it.
- The display will flash **"Ani "** 2 times then show the current weight, 0.00. and the Animal/Dynamic weighing symbol  will appear. The scale is now ready to weigh.

6.8.1 ANIMAL WEIGHING PROCEDURE

- With the platform empty the display will show zero weight. Place containers or blankets onto the platform and press the [→0/T←] key to zero the display. The scale may go into the animal (dynamic) weighing procedure when the items are placed on the scale but will return to showing zero when the [→0/T←] key is pressed.
- Place the animal or sample to be weighed on the platform.
- The display will show the Animal/Dynamic weighing symbol  while a stable weight is determined. The time it takes for the stable value will depend upon the setting of the filter parameter in the first step.
- When a stable reading is found, the display will show this value, and the display will be locked until the [→0/T←] key is pressed. The display will show the “Hold” symbol while the display is locked.

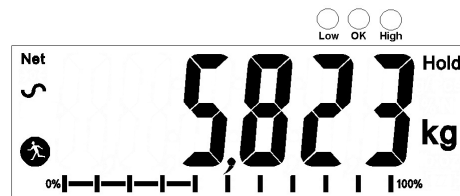

- To weigh a second subject press the [→0/T←] key if necessary to zero the display, and place the next animal on the scale. The scale will detect the new weight and hold it as before.
- The scale will remain in the animal weighing mode until the [Unit/←] key is pressed. Then it will return to normal weighing.

7.0 USER PARAMETERS

Pressing the [Func/C] key during normal operation allows the user to access the parameters for customizing the scale. The parameters are split into 4 groups:-

1. Check weighing parameters,
2. Percent and Animal Weighing Functions
3. RS-232 parameters
4. Scale parameters

- When [Func/C] key is pressed, display will first show “**FunC 1**” for Check weighing parameters.
- Press either the [Func/C] key or the [Pcs/↑] to advance through the groups “**FunC 1**”, “**FunC 2**”, “**FunC 3**” and “**FunC 4**”. When the required function is displayed, press [→0/T←] to enter the sub-menu for setting desired parameters for this function.
- When in one of the sections press [Print/M+/Esc] to regress one step each time. If you press [Print/M+/Esc] repeatedly, you will exit the User Parameter section and return to normal weighing.

7.1 CHECK WEIGHING PARAMETERS

See section 6.5 for details of using this special weighing mode.

This group of parameters-

- Set low and high limits for check-weighing
- Enables or disables the check weighing alarm
- Enables or disables the negative check weighing
- Press the [Func/C] key, then [→0/T←], to access the “**FunC 1**” settings group “**F1 Lo**” parameter.
- Press [→0/T←] to enter the settings sub-menu and then use the [Unit/←] key and [Pcs/↑] key to select and change the required weight values for the low limit.
- Press [→0/T←] to confirm the selection and return to “**F1 Lo**”. Advance to the next parameter “**F2 Hi**” by pressing the [Pcs/↑] key and then [→0/T←] to enter the settings sub-menu. Repeat the above steps to set values for “**F3 bEP**” and “**F4 nCt**”

Parameter	Description	Options	Default setting
F1 Lo	Set Low limit.	Use the [Unit/←] key and [Pcs/↑] key to set	000000

		the values of the lower limit. When set press the [→0/T←] key to store the value and go to F2 Hi	
F2 Hi	Set High limit.	Use the [Unit/←] key and [Pcs/↑] key to set the values of the high limit. When set press the [→0/T←] key to store the value and go to F3 bEP	000000
F3 bEP	This parameter sets the Beeper to off or on. If set to on, the beeper can further be set to sound when the weighing result is within or outside the check-weighing limits.	bP oFF - Off bP inL - Within limits bP otL - Outside limits (>20d)	bP inL
F4 nCK	This parameter enables negative check weighing function with ability to do negative tare.	on oFF	on

7.2 PERCENT WEIGHING AND ANIMAL WEIGHING

See section 6.7 and 6.8 for details of using these special weighing modes.

- Press **[→0/T←]** to enter a parameter. Use the **[Unit/←]** key and **[Pcs/↑]** key to set the values or just the **[Pcs/↑]** key to select the options.
- Press **[→0/T←]** to confirm the change and then advance to the next parameter by pressing the **[Pcs/↑]** key.
- Press **[Print/M+/Esc]** to return to the group **"Func 2"**. If you press **[Print/M+/Esc]** again, the scale will exit the User Parameter section and return to weighing.

Parameter	Description	Options	Default setting
P1 Pct	This parameter allows the user to enter the Percent weighing Function. See Section 6.7.	None	Enabled always

P2 Ani	Enter the Animal Weighing mode of operation, See section 6.8	Set the filter value.	Enabled Always
---------------	--	-----------------------	----------------

7.3 RS-232 PARAMETERS

- Press [**→0/T←**] to enter a parameter. Use the [**Unit/←**] key and [**Pcs/↑**] key to set the values or just the [**Pcs/↑**] key to select the options.
- Press [**→0/T←**] to confirm the change and then advance to the next parameter by pressing the [**Pcs/↑**] key.
- Press [**Print/M+/Esc**] to return to the group "**Func 3**". If you press [**Print/M+/Esc**] again, the scale will exit the User Parameter section and return to weighing.

This group of parameters can be configured by the user for setting the RS-232 active or not, baud rate, printing mode, accumulation mode, RS-232 language, and user or scale ID numbers.

Parameter	Description	Options	Default Values or setting
C1 on	Enable or disable the RS-232 interface	Prt on Prt off	Prt on
C2 bd	Baud Rate	600 1200 2400 4800 9600 19200	9600
C3 PrM	Printing Mode- Manual, Continuous or Automatic	mAn , Cont (not on EC approved scales) Auto	mAn
C4 Aon	Enable or disable the Accumulation	AC on AC off	AC on
C5 Ln	Select Language	EnGLi (English) FrEnCH (French) GErmAn (German) SPAn (Spanish)	EnGLi
C6 Uld	Set User ID	To be entered manually	000000
C7 Sid	Set Scale ID	To be entered manually	000000

Scale will perform the following, depending on the Accumulation and Print Settings:

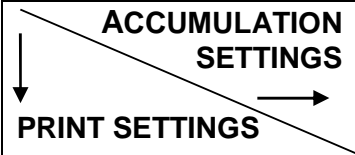
	AC on	AC Off
AUTO	Accumulate and print automatically	Print automatically, Do not accumulate
mAn	Accumulate and Print only when [Print/M+/Esc] key pressed. If [Print/M+/Esc] is pressed a second time only print the weight.	Print when [Print/M+/Esc] key is pressed, Do not accumulate.
Cont	Print continuously. Accumulate when [Print/M+/Esc] key is pressed	Print continuously. Do not accumulate.

7.4 SCALE PARAMETERS

- Press **[→0/T←]** to view the list of parameters.
- Press **[→0/T←]** to enter a parameter. Use the **[Unit/←]** key and **[Pcs/↑]** key to set the values or just the **[Pcs/↑]** key to select the options.
- Press **[→0/T←]** to confirm the change and then advance to the next parameter by pressing the **[Pcs/↑]** key.
- Press **[Print/M+/Esc]** to return to the group **“Func 4”**. If you press **[Print/M+/Esc]** again, the scale will exit the User Parameter section and return to normal weighing.

This group of parameters is used to control the operation of the scale.

Parameter	Description	Options	Default setting
S1 Un	Enable or disable weighing units, will not allow to disable all units, at least one has to be enabled. Parts counting can be enabled/disabled	Kg Grams lb oz lb:oz N (Newtons) PCS	Kg
S2 bl	Backlight set to always on, always off or automatic on whenever a weight is placed or a key is pressed	EL off EL on EL AU	EL AU
S3 AoF	Auto Off- Disable or set time increment to turn off scale	SLP 0 SLP 1 SLP 5 SLP 10	SLP 0
S4 dt	Set Time and Date format and settings. Format for date can be changed when the display shows mmddyy, ddmmyy or yymmdd by pressing the [Pcs/↑] key, then enter the date.	Enter the time manually. Enter the date format and then the numeric value manually.	00:00:00 mm:dd:yy
S5 diS	Display all weights or only when stable	ALL, StAb	ALL
S6 Fi	Filter setting to slow, normal or fast	Slow, nor, FAST	nor
S7 SPS	Password	Enter new password twice. Controls access to Func 1 to Func 4	Not active
S8 CAL	Calibration	Calibrate the scale. See Section 11.0	-

8.0 BATTERY OPERATION

- The scales can be operated from the battery if desired. The battery life can be up to 70 hours depending on the load cells and how the backlight is used.
- A battery symbol is shown on the display which indicates the current charge of the battery, 3 bars means fully charged. When just the outline of the battery and no bars are visible the battery needs to be re charged.
- To charge the battery, simply plug the adaptor into the mains power, and also into the input connector on the rear of the Indicator marked DC 12V. The scale does not need to be turned on.
- The battery should be charged for 12 hours to reach full capacity.
- Near the display is an LED to indicate the status of battery charging. When the scale is plugged into the mains power the internal battery will be charged. If the LED is green the battery has a full charge. If it is red the battery is nearly discharged and yellow indicates the battery is being charged.

9.0 RS-232 INTERFACE

The Warrior indicator is supplied with bi-directional RS-232 interface as standard. The scale, when connected to a printer or computer outputs the weight with the selected weighing unit through the RS-232 interface.

Specifications:

RS-232 output of weighing data

ASCII code

600 - 19200 Baud (user selectable, default 9600)

8 data bits

No Parity

1 stop bit

No flow control

RS-232 serial interface plug (As viewed from the back of the indicator):

- 1: Pin GND, Signal Ground
- 2: Pin RXD, Received Data
- 3: Pin TXD, Transmitted Data
- 4: Not connected

The scale can be set to print text in English, French, German or Spanish. See the RS-232 parameters section for details.

Data Format - Normal Output:

```
<cr><lf>
<cr><lf>
Date          12/09/2006 <cr><lf>
Time          14:56:27  <cr><lf>
<cr><lf>
Scale ID      123456  <cr><lf>          If ID is zero, it is left blank
User ID       234567  <cr><lf>
<cr><lf>
Net Wt        1.234 Kg  <cr><lf>          Net Wt. (or Gross Wt.)
<cr><lf>
<cr><lf>
<cr><lf>
<cr><lf>
```

Only weight value along with the weighing unit is printed. If Percent weighing is used then % is shown in place of weighing units.

Data Format - Parts Counting Output:

Weight, Unit weight and number of parts are printed.

```
<cr><lf>
<cr><lf>
Date          12/09/2006 <cr><lf>
Time          14:56:27  <cr><lf>
<cr><lf>
Scale ID      123456  <cr><lf>
User ID       234567  <cr><lf>
<cr><lf>
Net Wt.       1.234 Kg  <cr><lf>          Net Wt. (or Gross Wt.)
Unit Wt.      123 g    <cr><lf>          g for metric and lb for pounds
PCS           10 pcs  <cr><lf>
<cr><lf>
<cr><lf>
<cr><lf>
<cr><lf>
```

Data Format - Memory Recall Output:

```

<cr><lf>
Date          12/09/2006 <cr><lf>
Time          14:56:27  <cr><lf>
<cr><lf>
Scale ID      123456  <cr><lf>
User ID       234567  <cr><lf>
<cr><lf>
-----<cr><lf>
TOTAL
No.           5      <cr><lf>
Wt.          1.234 Kg <cr><lf>
<cr><lf>
PCS           10 pcs <cr><lf>
-----<cr><lf>
<cr><lf>

```

Data Format - Continuous Output, Normal weighing:

```

ST,GROSS  1.234 Kg <cr><lf>
US,NET    0.000 Kg <cr><lf>

```

ST or US for STable or UnStable,
NET or GROSS for Net Weight
or Gross wt. and the weighing unit, kg, lb etc.

Data Format - Continuous Output, Parts Counting:

```

ST Net     1.234 Kg <cr><lf>
U.W.      123 g   <cr><lf>
PCS       10 pcs <cr><lf>
<cr><lf>
<cr><lf>

```

Net Weight (or Gross wt.)
Kg and g for metric and Lb for pounds

NOTE:

1. The accumulated total will not be sent to the RS-232 when the continuous print is turned on.
2. The continuous print will only be for the current weight and the display data.
3. In other languages the format is the same but the text will be in the language selected.

Description	ENGLISH	FRENCH	GERMAN	SPANISH
Net weight	Net Wt.	Pds Net	Net-Gew	Pso Net
Weight per unit counted	Unit Wt.	Pds unit	Gew/Einh	Pso/Unid
Number of items counted	Pcs	Pcs	Stck.	Piezas

Number of weighing added to subtotals	No.	Nb.	Anzhl	Num.
Total weight and count printed	Total	Total	Gesamt	Total
Print date	Date	Date	Datum	Fecha
Print time	Time	Heure	Zeit	Hora
Scale ID number	Scale ID	Bal ID	Waagen ID	Bal ID
User ID Number	User ID	Util ID	Nutzer ID	Usuario ID

9.1 **INPUT COMMANDS FORMAT**

The scale can be controlled with the following commands. Press the **[Enter]** key of the PC after each command.

T<cr><lf>	Tares the scale to display the net weight. This is the same as pressing [→0/T←] .
Z<cr><lf>	Sets the zero point for all subsequent weighing. The display shows zero.
P<cr><lf>	Prints the results to a PC or printer using the RS-232 interface. It also adds the value to the accumulation memory if the accumulation function is not set to automatic.

10.0 RELAY INTERFACE

The Warrior indicator is supplied with drivers to control external relays. The drivers can be used to control a number of different relays depending upon the users need. The relay drivers are isolated outputs requiring the use of an external power supply for the relays.

The output to drive external relays is on the circuit board inside the enclosure. To gain access you must remove the 6 screws securing the front to the rear of the case. Pass the wires for the relays through the grommet on the rear panel. The wires will connect to the PCB using the terminal strip P1.

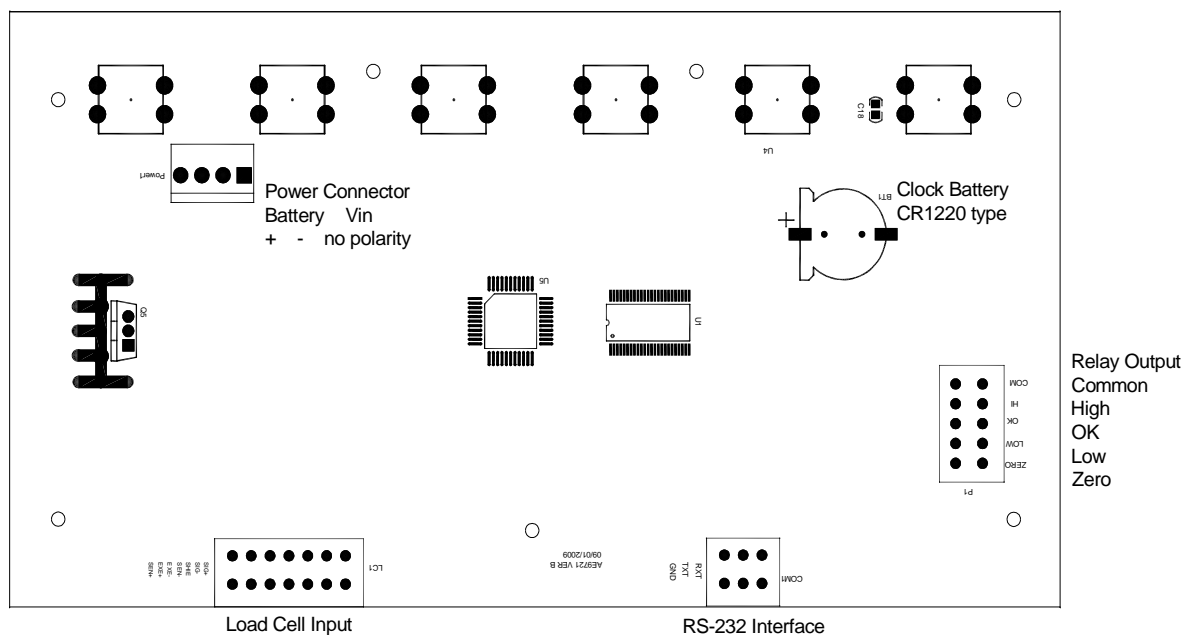

The circuit to control the relays requires an external voltage compatible with the relays used.

Contact Adam Equipment or your supplier for a relay interface that is compatible with the relay drivers, however other interfaces can be used as long as the following conditions apply.

Connections to the relay drivers:

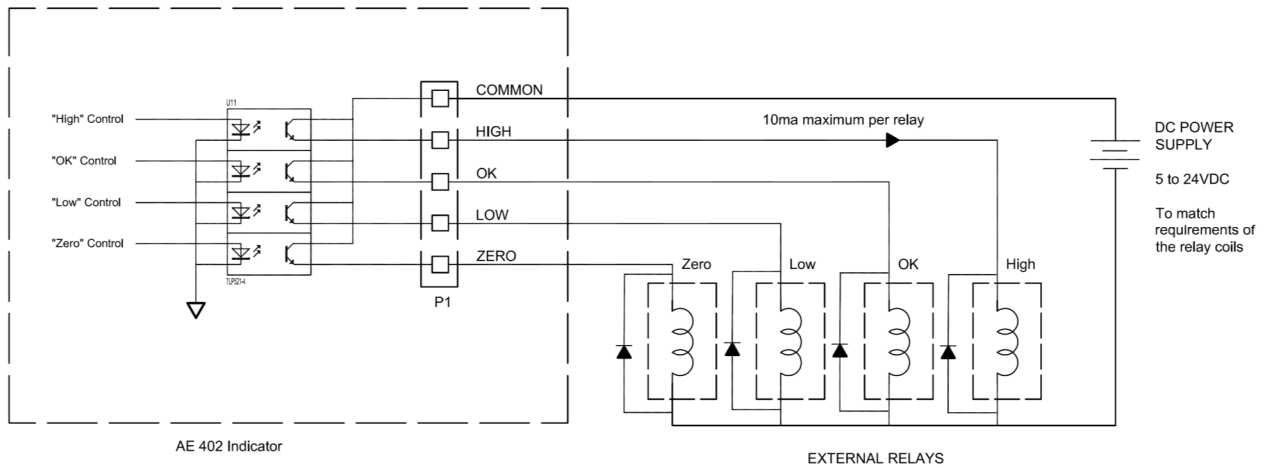

Connections are made to the PCB, Connector P1. The connector is a spring activated type, simply press on the top of the connector and insert the wire.

Do not exceed the safe limits of voltage or current of 24VDC or 15ma per output.

Depending upon the application it may be necessary to use a small relay to drive larger relays, or to provide additional protection to prevent electromagnetic interference (diodes as shown above) to this or other machinery.

11.0 CALIBRATION

The scale can be calibrated using the following procedure. To enter this procedure it is necessary to use Func 4 which is accessible using the **[Func/C]** key as described in section 7.4 in the full manual, or by using the passcode access as described in section 12.0.

The scales calibrate using either metric or pound weights depending on the weighing unit being used before calibration. The display will show either "kg" or "lb" to identify the weights expected.

PROCEDURE

- Enter the calibration section using Func 4, C8 CAL or using the passcode as described in section 12.0.
- The display will show "**unLoAd**".
- Remove any weight from platform and when the stable symbol is on press **[→0/T←]**.
- The display will show "**Ld**" then "**0000XX**" which shows the last calibration weight used. Place this calibration weight on the scale and press the **[→0/T←]** key. If the weight you put on the scale does not match the value displayed, press the **[Func/C]** key to clear the value then use the **[Unit/←]** key and **[PCS/↑]** key to set the correct value. When it is correct press **[→0/T←]**.
- If the calibration is acceptable the scale will run a self-test during which the calibration weight should be removed. If an error message "**FAIL**" is shown try calibration again as a disturbance may have prevented a successful calibration.

After calibration the scale should be checked to verify the calibration is correct. If necessary repeat the calibration making sure that the scale is stable before accepting any weight.

12.0 SERVICE PARAMETERS

The scales will allow entry to the parameters if the **[Tare]** key is pressed during the power on cycle. The passwords work as above.

In this case the display will show the passcode request screen, "**P-----**". To continue enter a passcode as described below.

Entering passcode 0000 will allow calibration as shown in section 11.

Entering 1000 will allow access to a limited set of parameters described in section 12.1.

12.1 *USING "1000" TO ENTER THE SERVICE PARAMETERS*

Press the **[→0/T←]** key during the display counting when turned on,

When "**Pn**" is displayed, enter the number 1000 using the **[Unit/←]** and **[Pcs/↑]** keys and then press **[→0/T←]**.

The displays will show the first parameters, called "**F4 Int**".

To select another parameter press the **[Pcs/↑]** key to advance through the parameters.

Press the **[→0/T←]** key to enter a parameter.

To exit a parameter, press the **[Print/M+/Esc]** key.

The display will show the parameter number and a name.

When a parameter is entered by pressing the **[→0/T←]** key, the displays will guide you through the parameter selected and the options available.

The parameters available are:

"F4 Int"	Initial Zero Range
"F5 rEZ"	Re-Zero range
"F6 SCS"	Successive Tare Enable
"F7 Cnt"	Display the A/D counts
"F8 Zem"	Zero Mode
"F9 Lvd"	Low voltage detection
"FA AZn"	Auto Zero Range
"Fb FPS"	User Function Password

The description of the parameters is shown below

12.2 USING THE SERVICE PARAMETERS

12.2.1 F4 –INITIAL ZERO RANGE

To enter this parameter, press the [**→0/T←**] key when **"F4 int"** is shown. The display will show the current initial zero range. Press the [**Pcs/□**] key to change the value and press [**→0/T←**] to accept the value. Press [**Print/M+/esc**] to return to weighing.

12.2.2 F5 -RE-ZERO RANGE

To enter this parameter, press the [**→0/T←**] key when **"F5 rEZ"** is shown. The display will show the current re-zero range. Press the [**Pcs/↑**] key to change the value. Press [**→0/T←**] to accept the value. Press [**Print/M+/esc**] to return to weighing.

12.2.3 F6 -SUCCESSIVE TARE

To enter this parameter, press the [**→0/T←**] key when **"F6 SCS"** is shown. The display will show if the successive tare is on or off. Press the [**Pcs/↑**] key to change the value. Press [**→0/T←**] to accept the displayed value. Press [**Print/M+/Esc**] to return to weighing.

12.2.4 F7 –ADC COUNTS

To enter this parameter, press the [**→0/T←**] key when **"F7 Cnt"** is shown. This parameter allows you to view the A/D counts from the internal A/D converter. This can be an aid to service. Press the [**→0/T←**] key to return to the PARAMETER menu. Press the [**Print/M+/Esc**] key to return to weighing. Typical value at zero is 30,000-90,000 (approx.).

Typical value at full capacity is 500,000 (approx.).

12.2.5 F8 –ZERO MODE

To enter this parameter, press the [**→0/T←**] key when “**F8 ZEm**” is shown. Select the Zero mode desired. In all but special cases Zero Mode 1 is used. The other 2 zero modes are for unique locations in the world and effect the +/- range of the zero.

Press the [**Pcs/↑**] key to change the value.

Press [**→0/T←**] to accept the displayed value.

Press [**Print/M+/Esc**] to return to weighing.

12.2.6 F9 –LOW VOLTAGE DETECTION

This parameter allows detection of low voltage when the battery wears down. To enter this parameter, press the **[→0/T←]** key when **“F9 LVD”** is shown. The display will show if the LVD Mode is set to on or oFF. Press the **[Pcs/↑]** key to change the value. Press **[→0/T←]** to accept the displayed value. Press **[Print/M+/Esc]** to return to weighing.

12.2.7 FA –AZn Auto Zero Range

This parameter sets the auto zero range from 0 (Off) to 4d. Calibration and parameter counting function to be active. To enter this parameter, press the **[→0/T←]** key when **“FA AZn”** is shown.

The display will show if the current Auto Zero range.

Press the **[Pcs/↑]** key to change the value. Press **[→0/T←]** to accept the displayed value. Press **[Print/M+/Esc]** to return to weighing.

12.2.8 Fb –FPS User Function Password

This parameter set a password to control access to the user functions as described in Section 7. If the password is set to 0000 the control is disable and the user has free access to the functions.

To enter this parameter, press the **[→0/T←]** key when **“Fb FPS”** is shown.

The display will show **“P1- - - -”** Enter the new password code followed by **[→0/T←]** to accept.

The display will then show **“P2- - - -”** Enter the new password code again followed by **[→0/T←]** to accept. The same code number must be entered both times for the password to be set.

Press the **[Unit/←]** and **[Pcs/↑]** keys to enter the values. Press **[Print/M+/Esc]** to return to weighing.

13.0 ERROR CODES

ERROR CODES	DESCRIPTION	SUGGESTIONS
--oL--	Over-range	Remove weight from the scale. If the problem persists contact your dealer or Adam Equipment for assistance.
Err 1	Time Setting Error	Enter time using correct format and reasonable values. Format: hh:mm:ss
Err 2	Date Setting Error	Enter date using correct format and reasonable values. Format: yy:mm:dd
Err 4	Zero Setting Error	The scale was outside the normal zero setting range either when it was turned on, or when the [Zero] key was pressed. Remove weight from the scale and try re-zeroing again. Use the [→0/T←] key to set the display to zero value. If the problem persists contact your dealer or Adam Equipment for assistance.
Err 6	A/D out of range	The values from the A/D converter are outside the normal range. Remove the weight from the scale if overloaded. Make sure the pan is fitted correctly. Indicates the load cell or the electronics may be faulty. If the problem persists contact your dealer or Adam Equipment for assistance.
Err 7	100% weight out of range	Weight value set as 100% for percentage weighing must be greater than 50 weighing divisions of the scale.
Err 9	Check weigh limits error	Shown if the low limit is set higher than the current high limit. Reset High limit or change the low limit.
FAIL	Calibration error.	Improper calibration (should be within $\pm 10\%$ of the factory calibration). The old calibration data will be retained until the calibration process is complete. If the problem persists contact your dealer or Adam Equipment for assistance.

14.0 REPLACEMENT PARTS AND ACCESSORIES

If you need to order any spare parts and accessories, contact your supplier or Adam Equipment. A partial list of such items is as follows:-

<ul style="list-style-type: none">• Power Supply Module• Replacement Battery• Replacement feet• Replacement screws and brackets	<ul style="list-style-type: none">• Printer, printer paper etc.• RS232 connector cable• Replacement top pan• Relay interface parts
--	---

15.0 SERVICE INFORMATION

This manual covers the details of operation. If you have a problem with the scale that is not directly addressed by this manual then contact your supplier for assistance. In order to provide further assistance, the supplier will need the following information which should be kept ready:

A. Details of your company

- Name of your company:
- Contact person's name:
- Contact telephone, e-mail,
- Fax or any other methods:

B. Details of the unit purchased

(This part of information should always be available for any future correspondence. We suggest you to fill in this form as soon as the unit is received and keep a print-out in your record for ready reference.)

Model name of the scale:	
Serial number of the unit:	
Software revision number (Displayed when power is first turned on):	
Date of Purchase:	
Name of the supplier and place:	

C. Brief description of the problem

Include any recent history of the unit. For example:

- Has it been working since it's delivered
- Has it been in contact with water
- Damaged from a fire
- Electrical Storms in the area
- Dropped on the floor, etc.

16.0 WARRANTY INFORMATION

Adam Equipment offers Limited Warranty (Parts and Labour) for any components that fail due to defects in materials or workmanship. Warranty starts from the date of delivery.

During the warranty period, should any repairs be necessary, the purchaser must inform its supplier or Adam Equipment Company. The company or its authorised Technician reserves the right to repair or replace the components at any of its workshops at no additional cost, depending on the severity of the problems. However, any freight involved in sending the faulty units or parts to the Service Centre should be borne by the purchaser.

The warranty will cease to operate if the equipment is not returned in the original packaging and with correct documentation for a claim to be processed. All claims are at the sole discretion of Adam Equipment.

This warranty does not cover equipment where defects or poor performance is due to misuse, accidental damage, exposure to radioactive or corrosive materials, negligence, faulty installation, unauthorised modifications or attempted repair, or failure to observe the requirements and recommendations as given in this User Manual.

This product may include a rechargeable battery that is designed to be removed and replaced by the user. Adam Equipment warrants that it will provide a replacement battery if the battery manifests a defect in materials or workmanship during the initial period of use of the product in which the battery is installed.

As with all batteries, the maximum capacity of any battery included in the product will decrease with time or use, and battery cycle life will vary depending on product model, configuration, features, use, and power management settings. A decrease in maximum battery capacity or battery cycle life is not a defect in materials or workmanship, and is not covered by this Limited Warranty.

Repairs carried out under the warranty do not extend the warranty period. Components removed during warranty repairs become company property.

The statutory rights of the purchaser are not affected by this warranty. The terms of this warranty is governed by the UK law. For complete details on Warranty Information, see the terms and conditions of sale available on our web-site.

EU Declaration of Conformity / Déclaration de conformité / Konformitätserklärung
Declaración de Conformidad / Dichiarazione di conformità



16

Year CE marking was first affixed to declared product

WARRIOR DIGITAL ELECTRONIC WEIGHING SCALE SERIES



Adam Equipment Co. Ltd.

Maidstone Road, Kingston
Milton Keynes, MK10 0BD

Tel: +44 (0) 1908 274545
Fax: +44 (0) 1908 641339

United Kingdom

Email: sales@adamequipment.co.uk

www.adamequipment.com

We declare under our sole responsibility that the balance models listed below marked with "CE" are in conformity with the directives and standards mentioned.

Nous déclarons sous notre seule responsabilité, que les types de balance cités ci-dessous munis de la mention "CE" sont conformes aux directives et aux normes mentionnées ci-après.

Wir erklären in alleiniger Verantwortung, dass die untenstehenden Waagentypen gekennzeichnet mit "CE" mit den genannten Richtlinien und Normen übereinstimmen.

Nosotros declaramos bajo responsabilidad exclusiva que los modelos de balanzas indicados a continuación con el distintivo "CE" son conformes con las directivas y normas citadas.

Noi dichiariamo sotto nostra unica responsabilità che i tipi di bilance specificati di seguito contrassegnati con la marcatura "CE" sono conformi alle direttive e norme citate.

Adam Equipment Model WARRIOR / WSK / WBK / WFK / WLK xxxx balances.

2014/30/EU	EN61326-1:2013 – Part 1
2014/35/EU	EN61010-1:2010 – Part 1:
2011/65/EC, RoHS 2	EN50581: 2012,

Signed for and on behalf of: Adam Equipment Company Ltd.
United Kingdom, 20 Feb 2016

Clive Jones, Quality & Product Manager.

WEEE 2012/19/EU

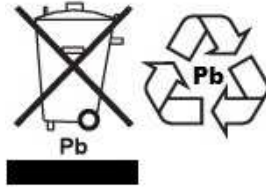

This device may not be disposed of in domestic waste. This also applies to countries outside the EU, per their specific requirements. Disposal of batteries (if fitted) must conform to local laws and restrictions.

Cet appareil ne peut être éliminé avec les déchets ménagers. L'élimination de la batterie doit être effectuée conformément aux lois et restrictions locales.

Dieses Gerät nicht mit dem Hausmüll entsorgt.

Dispositivo no puede ser desechado junto con los residuos domésticos

Dispositivo non può essere smaltito nei rifiuti domestici.

FCC / IC CLASS A DIGITAL DEVICE EMC VERIFICATION STATEMENT

NOTE: This equipment has been tested and found to comply with the limits for a Class A digital device, pursuant to Part 15 of the FCC rules and Canadian ICES-003/NMB-003 regulation. These limits are designed to provide reasonable protection against harmful interference when the equipment is operated in a commercial environment. This equipment generates, uses and can radiate radio frequency energy and, if not installed and used in accordance with the instruction manual, may cause harmful interference to radio communications. Operation of this equipment in a residential area is likely to cause harmful interference in which case the user will be required to correct the interference at his own expense.

CALIFORNIA PROPOSITION 65 - MANDATORY STATEMENT

WARNING: This product includes a sealed lead-acid battery which contains chemicals known to the State of California to cause cancer and birth defects or other reproductive harm.



Adam Equipment products have been tested with, and are always supplied with mains power adaptors which meet all legal requirements for the intended country or region of operation, including electrical safety, interference and energy efficiency. As we often update adaptor products to meet changing legislation it is not possible to refer to the exact model in this manual. Please contact us if you need specifications or safety information for your particular item. Do not attempt to connect or use an adaptor not supplied by us.

ADAM EQUIPMENT is an ISO 9001:2008 certified global company with more than 40 years' experience in the production and sale of electronic weighing equipment.

Adam products are predominantly designed for the Laboratory, Educational, Health and Fitness, Retail and Industrial Segments. The product range can be described as follows:

- Analytical and Precision Laboratory Balances
- Compact and Portable Balances
- High Capacity Balances
- Moisture analysers / balances
- Mechanical Scales
- Counting Scales
- Digital Weighing/Check-weighing Scales
- High performance Platform Scales
- Crane scales
- Mechanical and Digital Electronic Health and Fitness Scales
- Retail Scales for Price computing

For a complete listing of all Adam products visit our website at
www.adamequipment.com

<p>Adam Equipment Co. Ltd. Maidstone Road, Kingston Milton Keynes MK10 0BD UK Phone:+44 (0)1908 274545 Fax: +44 (0)1908 641339 e-mail: sales@adamequipment.co.uk</p>	<p>Adam Equipment Inc. 1, Fox Hollow Rd. 06478 USA Phone: +1 203 790 4774 Fax: +1 203 792 3406 e-mail: sales@adamequipment.com</p>	<p>AE Adam GmbH. Instenkamp 4 D-24242 Felde Germany Phone +49 (0)4340 40300 0 Fax: +49 (0)4340 40300 20 e-mail: sales@adamequipment.co.za</p>
<p>Adam Equipment S.A. (Pty) Ltd. 7 Megawatt Road, Spartan EXT 22 Kempton Park, Johannesburg, Republic of South Africa Phone +27 (0)11 974 9745 Fax: +27 (0)11 392 2587 e-mail: sales@adamequipment.co.za</p>	<p>Adam Equipment (S.E. ASIA) PTY Ltd 2/71 Tacoma Circuit CANNING VALE 6155 Perth Western Australia Phone: +61 (0) 8 6461 6236 Fax +61 (0) 8 9456 4462 e-mail: sales@adamequipment.com.au</p>	<p>Adam Equipment (Wuhan) Co. Ltd. A Building East Jianhua Private Industrial Park Zhuanyang Avenue Wuhan Economic & Technological Development Zone 430056 Wuhan P.R.China Phone: + 86 (27) 59420391 Fax + 86 (27) 59420388 e-mail: info@adamequipment.com.cn</p>

© Copyright by Adam Equipment Co. All rights reserved. No part of this publication may be reprinted or translated in any form or by any means without the prior permission of Adam Equipment.

Adam Equipment reserves the right to make changes to the technology, features, specifications and design of the equipment without notice.

All information contained within this publication is to the best of our knowledge timely, complete and accurate when issued. However, we are not responsible for misinterpretations which may result from the reading of this material.

The latest version of this publication can be found on our Website.

www.adamequipment.com